

# Level electric gauge JE100



- Tank height from 1250 to 3000 mm
- Transmission: angle drive
- Fitting: male 2" BSP
- Head housing: IP67
- 2 possible functions:
  - 1 or 2 contacts, potential free
  - 1 analogue output ( $\Omega$ ) + 1 contact

## APPLICATIONS

Level transmitter and alarm signals on low and high levels, are designed for indoor or outdoor tanks:

Liquid storage examples:

- Diesel
- Lubricating oil
- Glycol water
- Rainwater

They are particularly well adapted for storage or day-tank on diesel generators located outdoor.

## DESCRIPTION

Under the thrust of the fluid, the float transmits the level through an angle drive to a vertical stem.

The stem is then actuating a potentiometer (resistive output) and/or actuates contacts (alarms).

The electric gauge is mounted above the tank.

The complete system is supplied ready to install and to use.

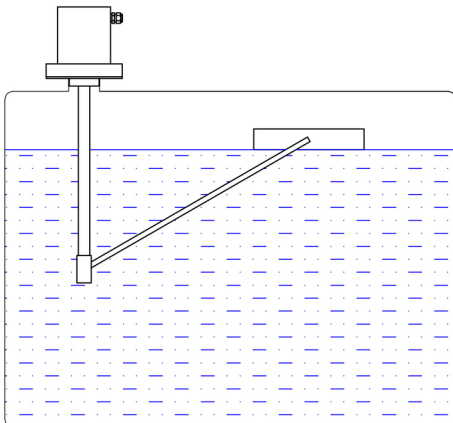

## TECHNICAL FEATURES

Materials	Steel, Nylon Float: Foamed PVC On request: Stainless steel (316L)
Flange seal:	Cork gasket
Mounting	BSP 2", male fitting
Head housing	Nylon, IP67 1 pressure gland 13 mm
Pressure	Atmospheric
Temperature	Between 0 and 40 °C
Contacts	Default setting: 1 or 2 contacts (2 way contact), 10 A, 230 V, potential free HIGH level alarm: 90 % LOW level alarm : 25 % On request: Factory adjustment between 20 and 90 %.
Continuous signal output	Resistive signal From 0 to 215 $\Omega$ (approx., $\pm 15\%$ )

# BAMO INTERNATIONAL

22, Rue de la Voie des Bans · Z.I. de la gare · 95100 ARGENTEUIL

Tel +33 (0)1 30 25 83 20 Web [www.bamo.eu](http://www.bamo.eu)  
Fax +33 (0)1 34 10 16 05 E-mail [export@bamo.fr](mailto:export@bamo.fr)

## Level electric gauge JE100

12-01-2021

D-579.03-EN-AC

NIV

579-03/1

579

579

## CODE NUMBERS AND REFERENCES

Code	Reference	Description
579 010	JE100	Resistor output ( $\Omega$ )
579 012	JE100 C	Resistor output ( $\Omega$ ) + 1 contact (LOW level alarm)
579 639	CF102 IP67	1 contact (LOW level alarm)
579 643	CF103 IP67	2 contacts (LOW and HIGH level alarms)

## DIMENSIONS

Dimensional (not to scale)

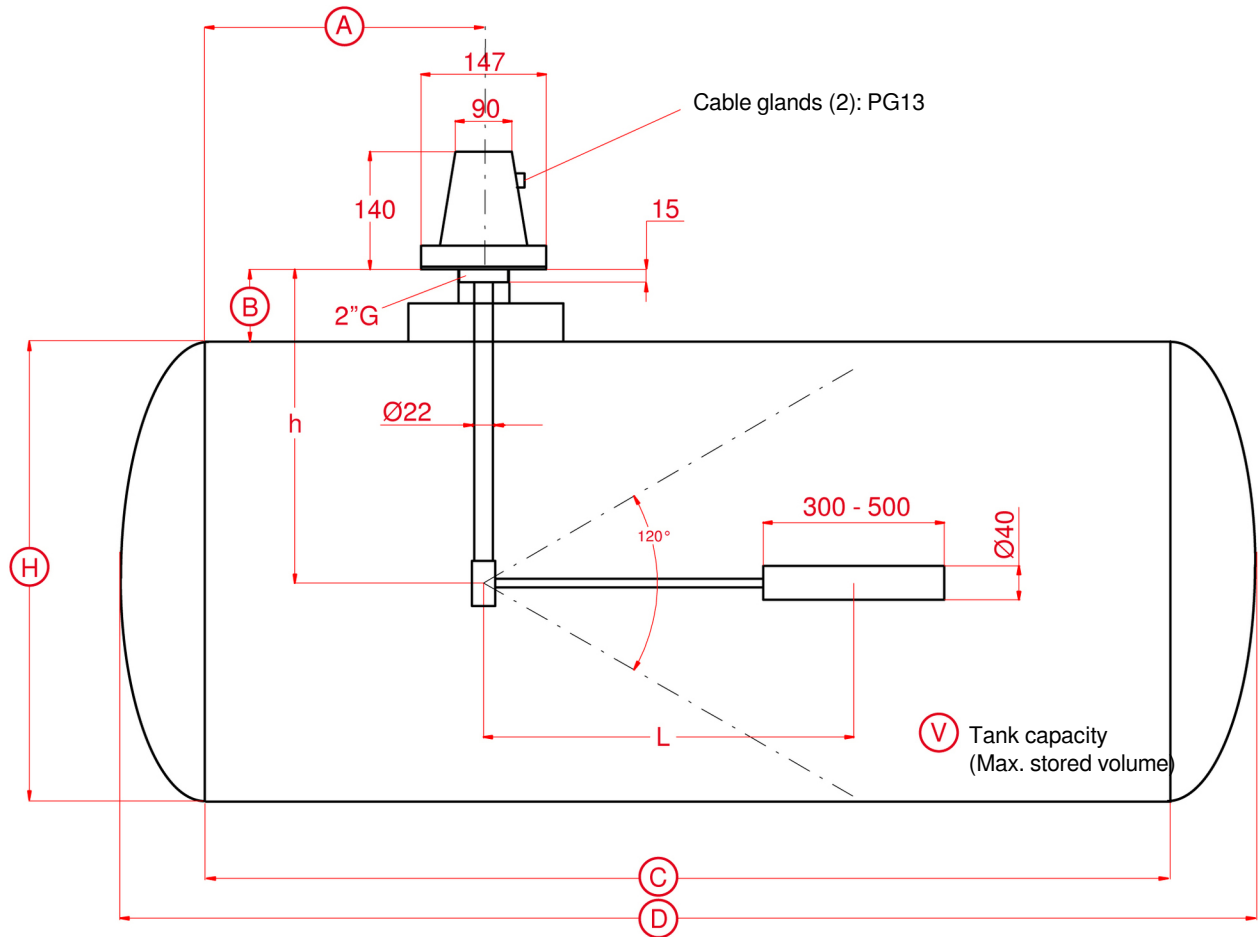

Dimensions A, B, C, D, H and V must be confirmed on purchase order.  
In case of a rectangular shaped tank, the width must be mentioned as well.

**BAMO** INTERNATIONAL

22, Rue de la Voie des Bans · Z.I. de la gare · 95100 ARGENTEUIL

Tel +33 (0)1 30 25 83 20 Web [www.bamo.eu](http://www.bamo.eu)

Fax +33 (0)1 34 10 16 05 E-mail [export@bamo.fr](mailto:export@bamo.fr)

Level electric gauge  
**JE100**

NIV

579-03/2

12-01-2021

D-579.03-EN-AC