

Inductive conductivity, PEEK probe TCL S50 series



- Measuring range from 10 $\mu\text{S}/\text{cm}$ up to 2000 mS/cm
- Construction: PEEK
- Wide chemical compatibility
- Temperature max. 125 °C
- Low fouling probe
- Built-in Pt100 sensor

APPLICATIONS

TCL S50 probe is designed for applications where high chemical resistance or high operating temperature are necessary:

- WWTP survey
- Concentration monitoring of acid and base (e.g.: NaOH, HNO₃, H₂SO₄ ...)
- Quality survey of chemicals in tank or pipeline
- Phase separation of mixture liquid/liquid

DESCRIPTION

TCL S50 probe is well adapted for measurement between 10 $\mu\text{S}/\text{cm}$ up to 2000 mS/cm .

It uses inductive measurement that offers many advantages. There is a total galvanic insulation between measuring loop and the liquid for reliable measurements on numerous chemicals.

PEEK material allows a wide range of chemical compatibilities and a long lifetime. Probe may also work at high temperature up to 125 °C.

Immersion measurement

The probe is fixed to end of probe holder for immersion, length from 500 to 2000 mm, with optional flange fitting.

On-line measurement:

Probe is mounted on a Te, ND 50 mm.

Complete measuring system includes:

- Inductive probe TCL S50, cable output.
- Fitting for: or immersion or on-line application.
- Converter: factory calibrated.
- Monitor BAMOPHAR TOR 364 (doc 364-04)

Monitors BAMOPHAR

BAMOPHAR 364 is designed for use of inductive probes.

Available ranges:

- 0- 2 mS/cm
- 0- 20 mS/cm
- 0- 200 mS/cm
- 0- 2000 mS/cm

Temperature compensation is done by BAMOPHAR, offering also an output 4-20mA, copy of temperature measurement.

Factory calibrations are done on each measuring system for a quick and easy start up on site.

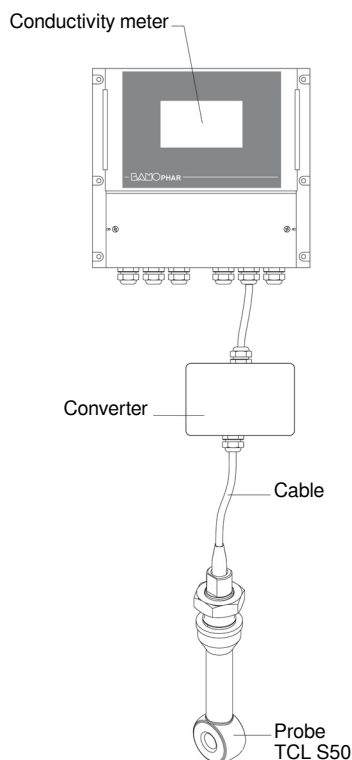

Complete system

BAMO INTERNATIONAL

22, Rue de la Voie des Bans · Z.I. de la gare · 95100 ARGENTEUIL

Tel +33 (0)1 30 25 83 20 Web www.bamo.eu

Fax +33 (0)1 34 10 16 05 E-mail export@bamo.fr

Inductive conductivity, PEEK
probe
TCL S50 series

03-07-2018

D-364.05-EN-AF

RES

364-05/1

TECHNICAL FEATURES

Measuring range	Conductivity: 10 μ S/cm up to 2000 mS/cm
Cell constant	c = 1.98 cm ⁻¹
Probe material	PEEK
Seal	FPM
Fitting	3/4" BSP
Ambient temperature	-10 ... +70 °C
Liquid temperature	-20 ... +125 °C
Temperature sensor	Built-in Pt 100 sensor (Class A - acc. IEC 60751)
Pressure	20 bar max.
Protection	IP 67 (NEMA 6)
	IP 68 with immersion probe holder
Output cable version	5 m long cable

CODE NUMBER AND REFERENCE

Code	Reference	Description
364 058	TCL S50	Inductive conductivity probe, PEEK, 3/4" BSP, 5 m cable output

NOTE:

Complete system always integrates a box for converter between the probe and the monitor BAMOPHAR 364.
The box will be fitted in factory on the top of probe holder (Immersion and Te holders).
Between the box and the monitor a specific cable C8B must be used (code 368108)

DIMENSIONS

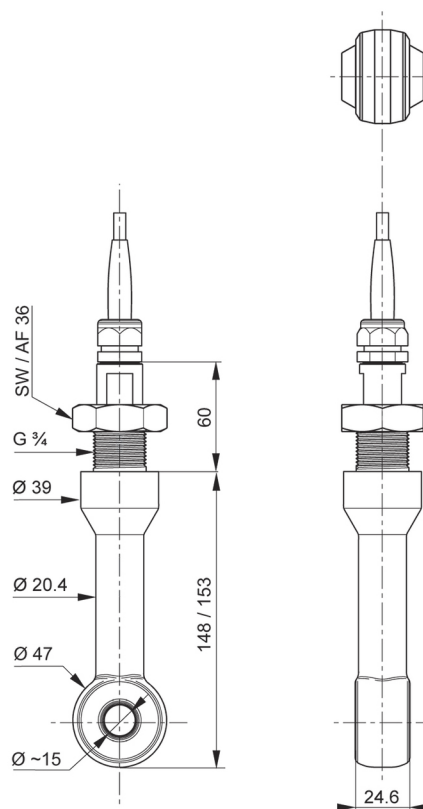

BAMO INTERNATIONAL

22, Rue de la Voie des Bans · Z.I. de la gare · 95100 ARGENTEUIL
Tel +33 (0)1 30 25 83 20 Web www.bamo.eu
Fax +33 (0)1 34 10 16 05 E-mail export@bamo.fr

Inductive conductivity, PEEK
probe
TCL S50 series

03-07-2018

D-364.05-EN-AF

RES

364-05/2